

CONTINUOUS TRAY SEALER

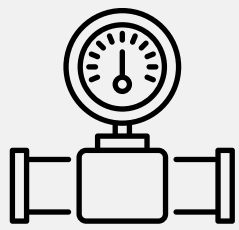

**Advanced Gas
Flushing**



**Extended
Shelf-Life**



**Hygienic & Safe
Design**



**Secured
Sealing**

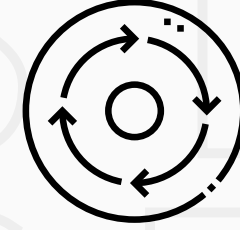

**Consistent
Quality**



**IP65
Standards**

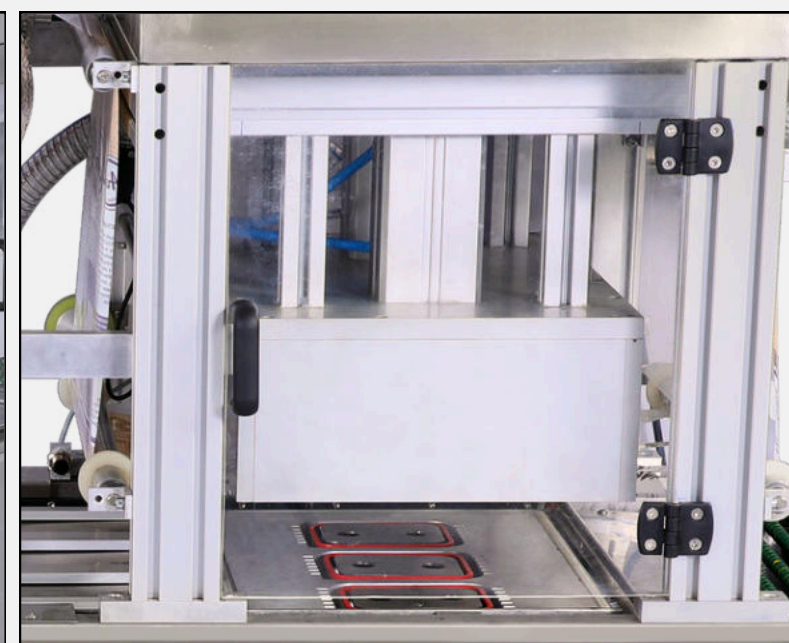
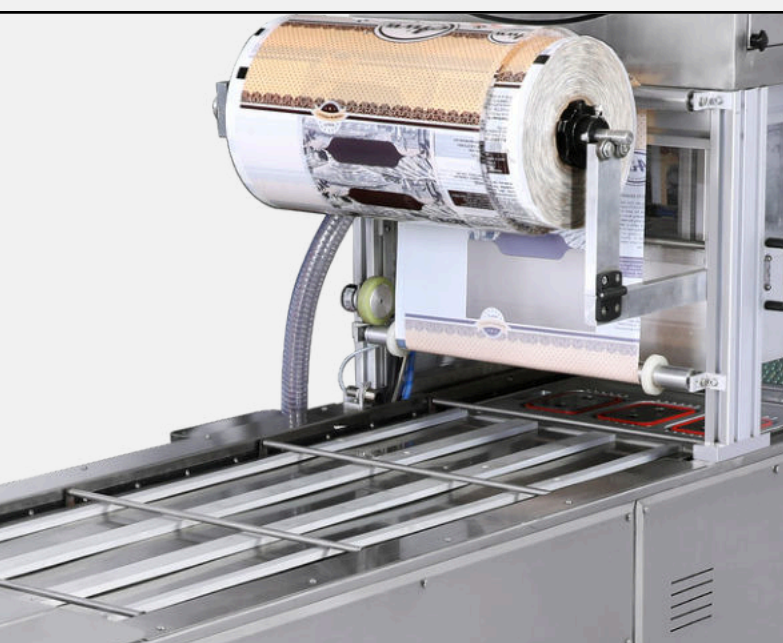

A continuous tray sealer machine is an automated packaging system designed to seal food or medical trays with a secure film cover. It operates continuously, enhancing production efficiency by sealing multiple trays in a fast, consistent process. It removes air from the package to extend shelf life by reducing exposure to oxygen, preserving freshness and preventing spoilage.

The continuous tray sealer offers customizable gas flushing options, ensuring extended shelf life and optimal product freshness.

The application is to preserve foods like sweets, dairy products, meat, seafood, dates, dry fruits & convenience foods etc.

Easy to Operate

Designed with simplicity, our machine features an intuitive smart interface and straightforward controls, ensuring easy operation for all experience levels.

Easy Maintenance

With a focus on convenience, our machine is engineered for easy maintenance, featuring accessible components and straightforward service procedures.

Rapid Tech Support

Benefit from our 24*7 rapid tech support, offering prompt assistance and solutions to minimize downtime and keep your machine running smoothly.

DIMENSIONS

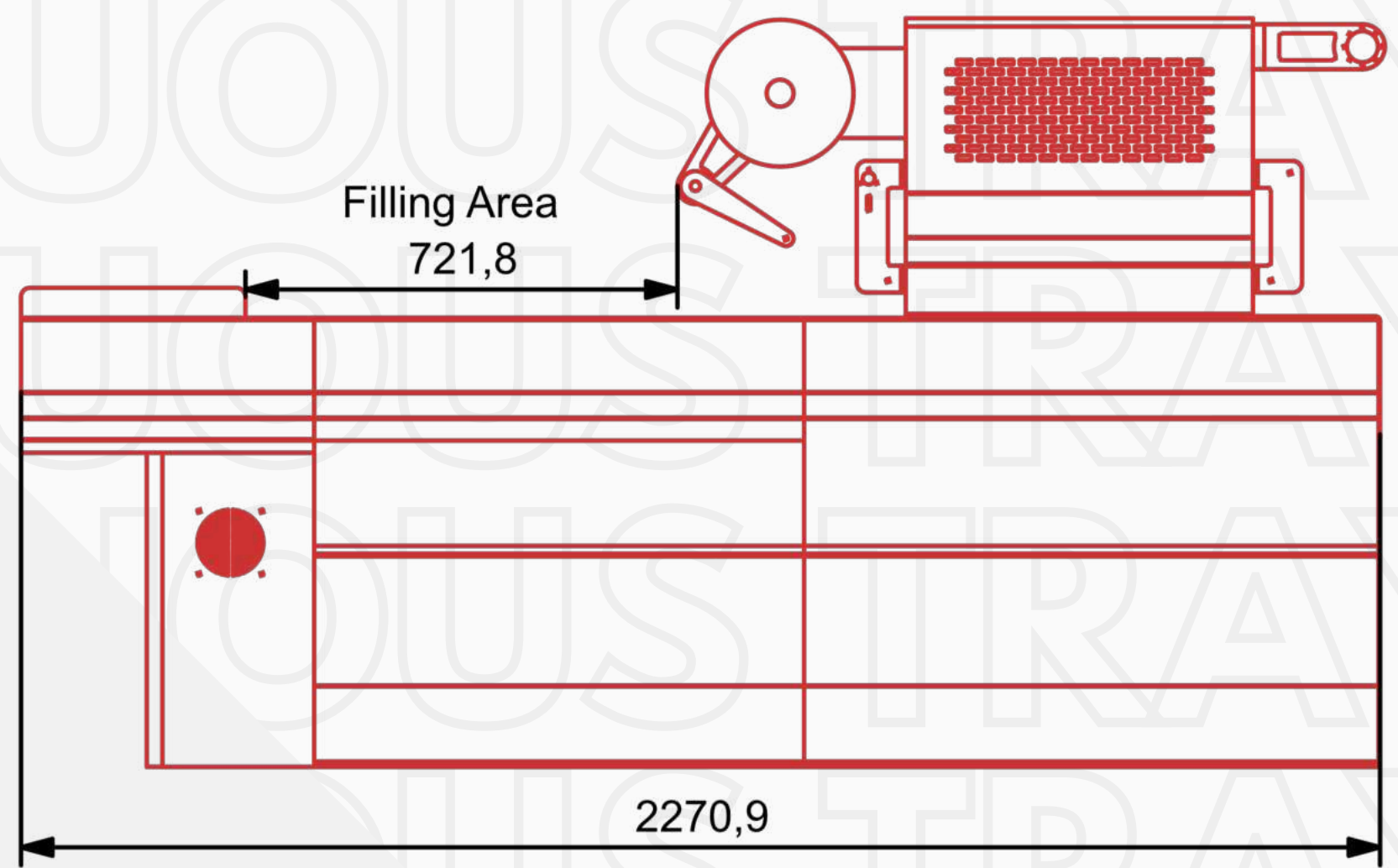
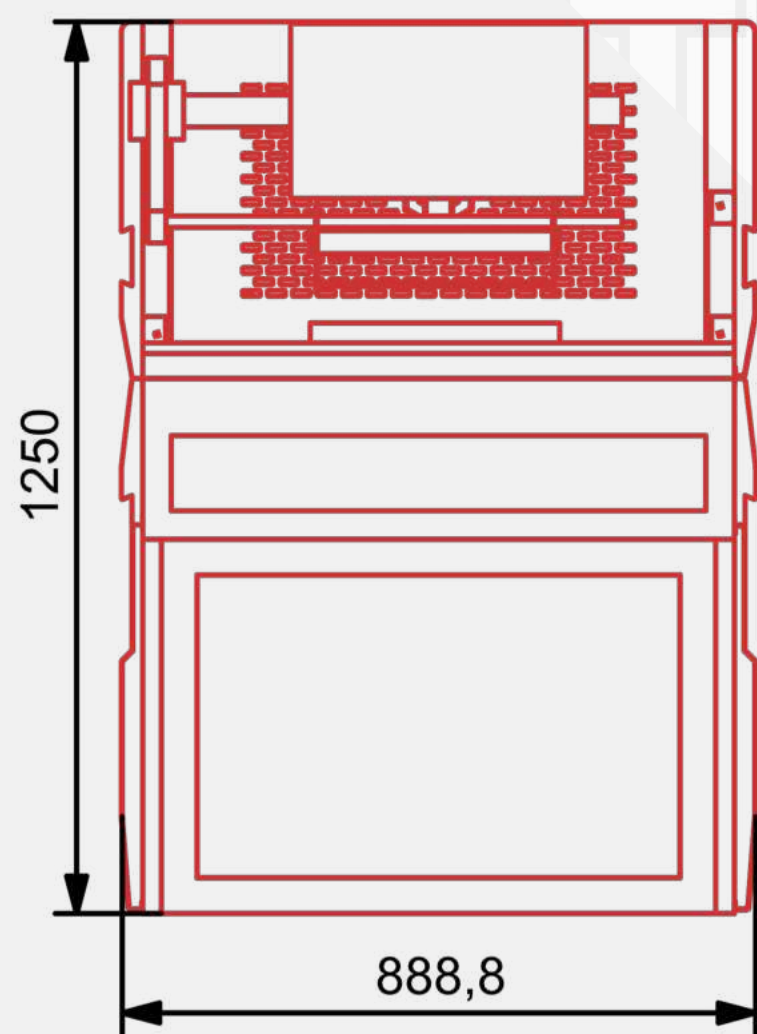

CONTICON 4

TECHNICAL SPECIFICATIONS

Production Capacity	Up To 5-6 Cycles Per Minute	Require Air Compressor	5 H.P.
Products	Sweets & Savories, Bakery	Air Pressure	6 - 7 Bar
Upper Film	Printed / Plain	Total Installed Power	6 KW
Tray Material	Rigid (Pre Formed)	Electrical Voltage	440V AC (3-Phase)
Tray Shape And Size	Customized	Machine Length	~ 2300 mm
Machine Construction	Stainless Steel 304 & Aluminum Assemblies	Machine Width	~ 890 mm
Vacuum Pump	Busch / Becker	Machine Height	~ 1250 mm
Control & Command System	PLC Touch Screen (Fuji)	Machine Weight	~ 550 Kg
Application	MAP, Sealing		

*The above mentioned values are indicative and can be modified at any time at the discretion of the company.